

# Abu Dhabi 2024

# iros

The IEEE/RSJ International Conference on  
Intelligent Robots and Systems (IROS 2024)  
14 – 18 October 2024 | ADNEC, Abu Dhabi, UAE

## SPONSORSHIP PROSPECTUS

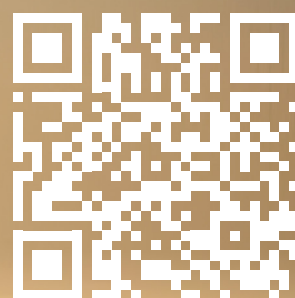

[iros2024-abudhabi.org](https://iros2024-abudhabi.org)

#### Partners



#### Hosted and Supported by



# Connect with more than 4000 leading roboticists!

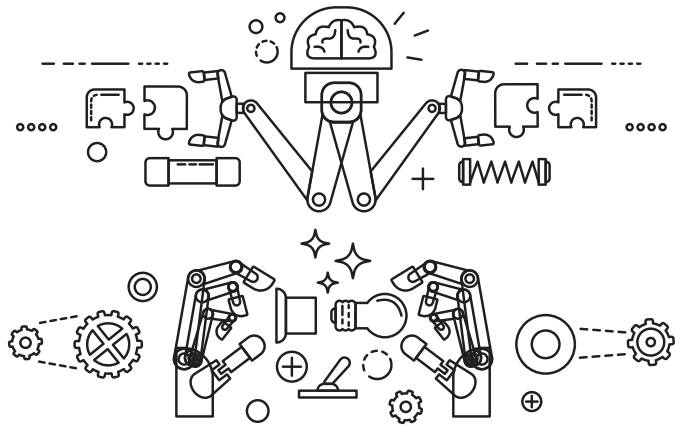

## Who will you meet?

### INDUSTRY LEADING ORGANIZATIONS

81% of attendees come from organizations of more than 100 employees with an emphasis on the university and research setting.

### DIVERSE PURCHASING INTEREST

Attendees come with a wide breadth of product interests.

### EXPERIECED ROBOTICISIST

Nearly 60% of attendees have 6 or more years of experience in Robotics.

### WIDE RANGING APPLICATIONS

Manufacturing (45%), healthcare (37%), logistics (28%), agriculture (21%), defense (18%), security (10%), mining (9%) represent the largest application interests.



# HOW TO GET INVOLVED

There are a variety of ways to partner at IROS 2024 - either as a sponsor, exhibitor or both, as detailed in this prospectus.

It is worth noting that our packages are designed to extend your brand messaging beyond the physical event into the realm of our considerable virtual audience.

We would also welcome your suggestions as to any alternative ways in which you might wish to support the event.

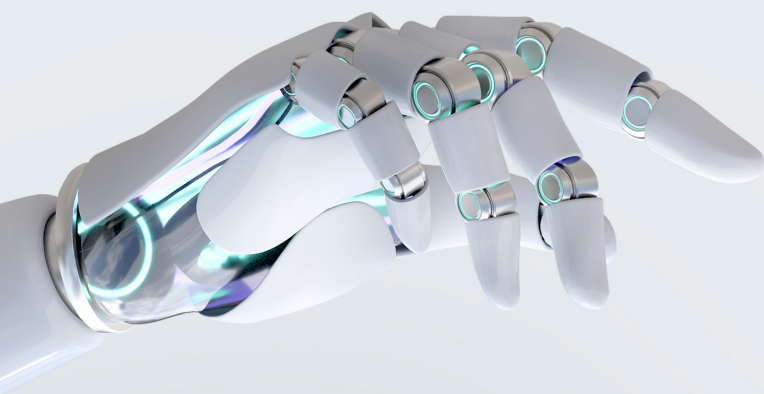

# PARTNERSHIP OPPORTUNITIES

Select from the following partnership packages that include benefits to enhance your brand before, during, and after the conference, along with a major presence in the exhibit hall.

Partnership Levels	Platinum	Gold	Silver	Bronze
<b>Brand Enhancement</b>	<b>60,000\$</b>	<b>40,000\$</b>	<b>20,000\$</b>	<b>10,000\$</b>
Hyperlinked logo on IROS 2024 website	✓	✓	✓	✓
Partner & Exhibitor directory listing in the Conference App	✓	✓	✓	✓
Logo on welcome signage at entrance to exhibit hall	✓	✓	✓	✓
Logo in Conference Pocket Guide	✓	✓	✓	✓
Logo on partnership acknowledgement slide prior to start of plenary and keynote sessions	✓	✓	✓	✓
Logo on pre-conference e-blasts/promotional materials	✓	✓	✓	
Recognition from conference chair in welcome address	✓	✓	✓	
Recognition on signage throughout convention center	✓	✓		
Insert in conference bag	✓			
Personalized alerts/push notifications in Conference App	2	1		
Access to Recruitment Program	3 months	3 months	2 months	2 months
Invitations to all VIP Events	2			
<b>Exhibition Space</b>				
Exhibit space (net square meters)	36	18	9	
<b>Registration Passes</b>				
Full conference delegate passes	8	6	3	1
Exhibitor personnel passes	12	8	6	

# CHOOSE FROM HIGH-PROFILE PARTNERSHIP OPPORTUNITIES OR DESIGN YOUR OWN

The following a la carte partnerships give you additional opportunities to make a positive impression with the IROS audience and enhance your brand image. Many are exclusive! If you don't see a partnership opportunity that fits your marketing objective, contact us to discuss how we can help you accomplish your goals at IROS 2024.

## SUPPORT OF ATTENDEES SERVICES

Conference T-shirts – exclusive	50.000\$
Conference Bag – exclusive	35.000\$
Badge and Lanyard – exclusive (printing/production/shipping charges are the responsibility of the partner. Distributed to all attendees)	15.000\$
Hydration Stations in the Exhibit Hall - 3 available	3.000\$
Charging Tables in the Exhibit Hall - 3 available	5.000\$
Connection Zone in the Exhibit Hall - exclusive	15.000\$
Conference Coffee Service in the Exhibit Hall 6 available	5.000\$

## SUPPORT OF SOCIAL EVENTS

Black in Robotics Luncheon — exclusive	15.000\$
Welcome Reception (Sunday) — 3 available	7.500\$
Farewell Reception (Wednesday) — 3 available	5.000\$

## SUPPORT OF EDUCATIONAL EVENTS

Conference App Partnership — exclusive	15.000\$
Poster Area in the Exhibit Hall — exclusive	7.500\$

## BRANDING IN THE CONVENTION CENTER

Signage in the Convention Center - multiple	Call for pricing
Advertising Banner in the Convention Center - multiple	Call for pricing
Aisle Sign Sponsorship in the Exhibit Hall - exclusive	15.000\$
Floor Decals in the Convention Center 2.5 x 2.5 4 available	5.000\$

# GET FACE-TO-FACE ACCESS TO THE TOP TALENT IN THE FIELD

We expect over 30% of the audience to be students. Check out their work and identify potential new hires for your organization. Remember – with any applicant who gets a paper accepted by IROS, you can be sure they’re among **the very highest caliber of robotics students and postdocs in the world!**

The Access to Recruitment Program is targeted at robotics companies of all sizes and provides an outstanding opportunity for employers to showcase their company and to conduct on-site interviews with prospective employees and interns. The Access to Recruitment Program is available only to IROS 2024 Partners and Exhibitors with fees as follows:

	PLATINUM/GOLD	SILVER/BRONZE
<b>CANDIDATES</b>	PH.D	PH.D
	M.Sc.	M.Sc.
	B.Sc.	B.Sc.
Access prior the conference	3 months	2 months
<b>Fee by organization site</b>		
More than 500 employe	10.000\$	7.000\$
101-500 employees	5.000\$	3.750\$
Less than 100 employees	2.500\$	1.875\$

# EXHIBITING

The Exhibit Hall will be a major component of the conference experience for all attendees. The conference program has been designed to maximize the opportunities for attendees to visit the exhibit hall to see the latest robotics technologies and products and network with exhibitors. A variety of activities will take place in the exhibit hall, including coffee breaks, poster sessions, and dedicated exhibit hall time during lunch each day. Reserve your exhibit space today!

EXHIBIT SPACE RENTAL (available in increments of 3 x 3)	
STANDARD BOOTH RENTAL	500\$ per sqm
START-UP BOOTH RENTAL	2.500\$ BOOTH PACKAGE (3X3)

## Exhibit Space Rental Includes:

- 1x exhibition table and 2x chairs / Back and side walls / Company name on fascia / 2x spotlights / 2x 13 AMP Power Socket / 1x Waste Bin
- Access to post-conference delegate list with email addresses and mailing information (GDPR compliant, opt-outs removed).
- Two (2) Exhibitor Personnel Passes per 100 sq. ft. of exhibit space. Additional Exhibitor Personnel Passes can be purchased.
- Complimentary access to the Welcome Reception and Farewell Reception with an Exhibitor Personnel Pass.
- Complimentary listing in the Conference Exhibit Directory that includes contact information, product description, logo, and link to website.
- Complimentary listing on the Conference mobile app.
- Complimentary Wi-Fi Internet access in the exhibit hall.
- Access to high-impact partnership opportunities available only to exhibitors.



# THE VENUE

The multi-award-winning Abu Dhabi National Exhibition Centre (ADNEC) is a state-of-the-art, fully interconnected venue within the hearth of Abu Dhabi.